

## INTELLIGENT DIGITAL MANOMETERS

## MANO GAUGE / MANO RECORD MANO CALI

This is a highly accurate microprocessor-controlled pressure measuring instrument. SensoBrain™, a KELLER-designed low power signal processor, transmits the signals of the pressure- and temperature sensor to the microprocessor, which digitally compensates the sensor data. This mathematical modelling of the pressure sensor virtually eliminates all errors over a wide temperature range. All KELLER- and KAVLICO-sensors are compatible with the electronics of the Intelligent Manometers.

### MANO GAUGE (Basic Version)

Display of: Pressure, Pressure Unit, Temperature, Elapsed Time  
 Alternative: Pressure, Pressure Unit, Max.- and Min. Value  
 All functions are executed with the front key of the instrument. It allows the display to be set to zero and to change the measuring cycle for prolonged battery life. Two pressure sensors can be connected to the MANO GAUGE (optional). Analog outputs can be provided 4...20 mA or 0...10 V (optional).

### MANO RECORD (MANO GAUGE plus data recording)

Based on the MANO GAUGE, the MANO RECORD records and stores the measured values. The front key is used to select which data shall be displayed and stored, and to set the recording interval and the number of readings (memory for 960 or optionally 8100 readings). The read-out of the stored data is via RS 232 serial interface (Logger Software and K101 cable available as option).

### MANO CALI (CALIBRATOR VERSION plus data recording)

In the basic mode, the MANO CALI displays: Pressure, Pressure Unit, Max.- and Min. Values. Units are selected via the front key (bar, PSI, kPa, MPa,...). MANO CALI also incorporates the functions TARA (sets a new temporary zero reference), LEAK (measures a pressure change over a programmable time) and RES (reduces the standard resolution by factor 10). A separate HOLD-key on the instrument freezes the reading. This instrument has the same data recording features as the MANO RECORD.

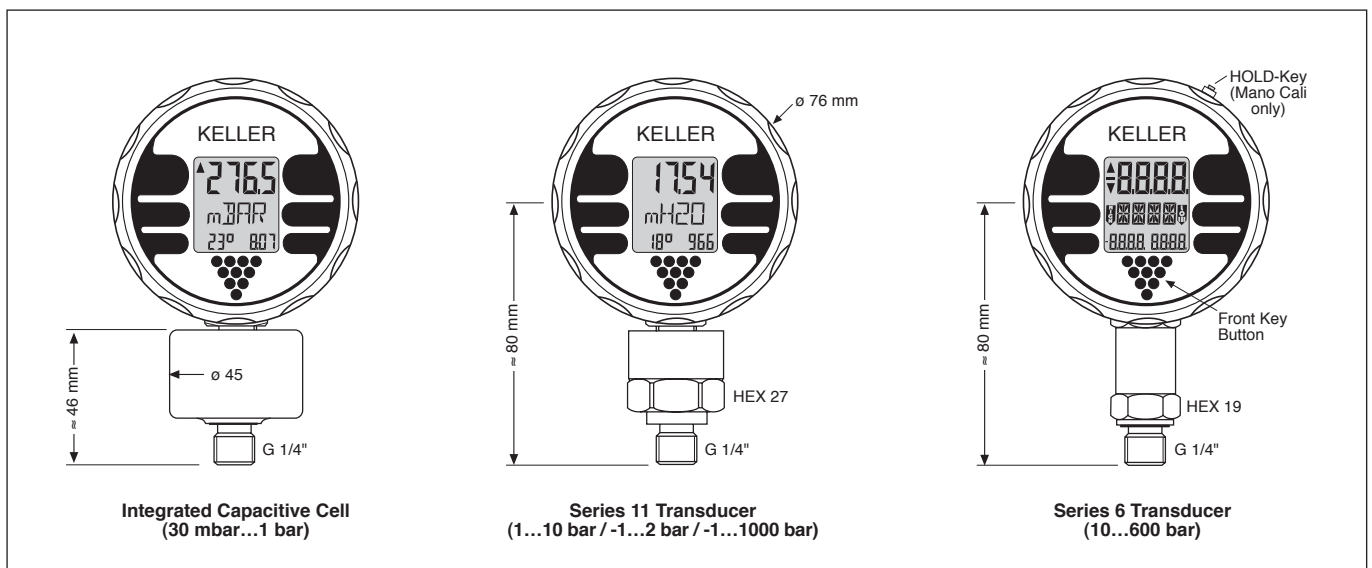



# KELLER

## SPECIFICATIONS

### MANO GAUGE / MANO RECORD

Vented Gauge or Absolute		Sealed Gauge or Absolute	
Range	Resolution	Range	Resolution
30 mbar	0,01 mbar	100 bar	0,03 bar
300 mbar	0,1 mbar	300 bar	0,1 bar
1000 mbar	0,3 mbar	600 bar	0,2 bar
-1...2 bar	1 mbar	1000 bar	0,3 bar
10 bar	3 mbar		
30 bar	10 mbar		

### MANO CALI

Sealed or Vented Gauge	
Range	Resolution
-1...2 bar	0,5 mbar
-1...10 bar	1,8 mbar
-1...25 bar	4,3 mbar
200 bar	0,03 bar
350 bar	0,05 bar
700 bar	0,1 bar

In MANO GAUGE and MANO RECORD the measuring ranges are divided by 12 bit or 3000 points. In MANO CALI over 13 bit or 6000 points.

The resolution is determined by the measuring range and the number of measuring points.

### • Specific Characteristics

	MANO GAUGE / RECORD	MANO CALI
Total Accuracy <sup>(1)</sup>		
Range 0...50°C	± 0,1% typ.	0,05 % typ.
	± 0,2% max.	0,1% max.
Measuring Interval <sup>(2)</sup>	sec	0,5
	≥ 0,5 (adjustable)	

<sup>(1)</sup> Includes linearity, repeatability, hysteresis, temperature and resolution of the display

<sup>(2)</sup> x 2 for two transducers (not for MANO CALI)

### • Environmental Characteristics

Operating Temperature	°C	- 10...60
Compensated Range <sup>(5)</sup>	°C	0...50
Storage Temperature	°C	- 30...80
Display <sup>(5)</sup>	°C	0...50

<sup>(5)</sup> others upon request

### • Electrical Characteristics

Supply	Lithium-Battery 3,6 V (included)
Battery-Life	> 200 days at continuous operation <sup>(4)</sup>
Output Signal (optional)	
- Analog <sup>(3)</sup> (MANO RECORD / GAUGE)	4..20 mA or 0..10 V
- Numerical (MANO RECORD / CALI)	RS 232

<sup>(3)</sup> The use of an analog signal requires an external supply between 10...28 VDC

<sup>(4)</sup> > 100 days for MANO CALI

### • Mechanical Characteristics

Manometer Housing	Polyamid 12
Transducer	See data sheet of transducer
Total Weight	approx. 250 g
Pressure Connection	See data sheet of transducer
Protection	IP 65

### • Options (on request)

- Manometer Housing in Metal\*
- 1 or 2 external Transducers (remote)\*
- Transmitter Output Connector\*
- Special Programs
- Logger Software and K101 Cable
- Intrinsically Safe Version (EEx-ia)\*

\* only MANO RECORD and MANO GAUGE

## LOGGER

The Logger-Software allows the read-out of the stored data from the Intelligent Manometer. The data transfer takes place via the serial interface on the PC.

The MANO RECORD / MANO CALI is connected through a cable K101 (supplied with Logger software).

The LOGGER-software offers many further processing possibilities of the read-out data, and meets all the requirements of modern Windows-Software:

- Graphical Display
- Tabulated Display
- Export into other Windows-Programs
- Storage into Files

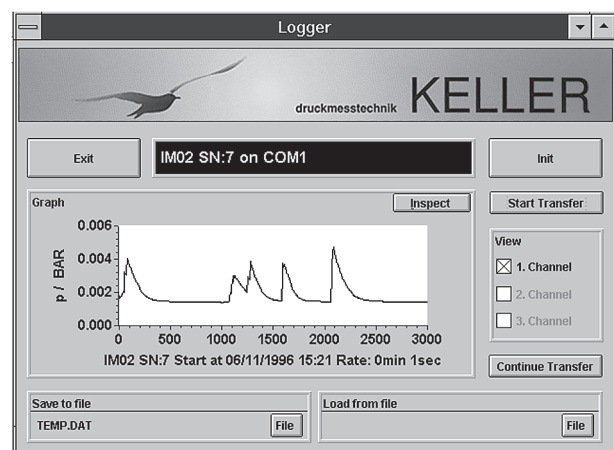

Subject to alterations

2/00

**KELLER AG für Druckmesstechnik**  
**KELLER Gesellschaft für Druckmesstechnik mbH**

St. Gallerstrasse 119  
 Schwarzwaldstrasse 17

CH-8404 Winterthur  
 D-79798 Jestetten

Tel. 052 - 235 25 25  
 Tel. 07745 - 9214 - 0

Fax 052 - 235 25 00  
 Fax 07745 - 9214 - 50